



KRENDL

#2100



Maximize your production with our #2100 **all-fiber** (airlock) machine, featuring a large 12 inch (30.5cm.) diameter by 16 inch (40.6cm.) long airlock. This unit is one of the highest production machines available in a portable electric model.

MATERIAL PRODUCTION RATE

lbs/hr (kg/hr) rating with 150ft. (45.8m.) of 4" (10.2cm.) hose at 16ft. (4.9m.) elevation

MATERIAL	MACHINE w/positive displacement blower lbs/hr (kg/hr)
CELLULOSE	3400 (1542)

Product density and variable blowing conditions will affect production rate.

STANDARD FEATURES

- modular component design
- safety guards and hopper bars
- flip-top hopper 16 cu. ft. (.44 m³)
- four (4) agitators (stainless steel)
- all steel airlock
- shredder assembly
- 2 hp. TEFC motor/reducer (1260 in./lb. torque)
- #50 nickel plate double chain/hardened steel sprockets
- 3 hp. TEFC motor and positive displacement blower w/ check valve protection, pressure relief, and filter design
- cord hanger / hand pendant holder

- pre-alarm buzzer
- main disconnect/power interruption shutdown
- emergency kill switch
- manual override at machine
- 150ft. (46m.) remote control cord/3 position switch
- deluxe voltmeter
- multiple auxiliary convenience outlets
- overload protection on transformer and all motors

Mechanical

- quick disassembly/reassembly for easy troubleshooting and maintenance
- operator safety
- quick easy access to airlock
- enhanced conditioning of fibers with no corrosion
- enhanced spraying and metering capabilities
- increased production and material conditioning
- durable direct drive transmission for the toughest blowing materials
- rugged, corrosion/abrasion resistant drive system
- increased blower efficiency and durability/less filter maintenance/ better protection of blower
- for remote control cord

Electrical

- operator safety/alerts operator **before** machine starts
- disconnects power to panel **before** allowing access/manual restart
- operator safety/quick hazard response
- operator safety/enhanced troubleshooting and control at machine
- operator safety/increased operator control of feed and blower
- indicator for low/high voltage protection of motors
- easy addition of accessory devices
- complete protection of all electrical components

BENEFITS

WEIGHT

992 lbs. (450 kg.)

DIMENSIONS

55"W x 29"D x 42"H
(140cm. W x 74cm. D x 107cm. H)

HOPPER CAPACITY

16 cu. ft. (.44 m³)
30 cu. ft. (.84 m³) w/Extension

AIRLOCK

16" x 12" diameter (40.6cm. x 30.5cm. diameter)
4" (10.2cm.) outlet for blowing hose

POWER REQUIREMENT

single input, 30amp/240volt/60hz
(consult factory for hook-up)

BLOWER/SIZES

positive displacement w/3hp motor
provides 135 CFM @ 4 1/2psi

RECOMMENDED GENERATOR

15,000 watts (for machine only)

SPECIFICATIONS

BLOWER	AIRLOCK PRESSURE (P.S.I.)	BLOWER RATING (C.F.M)	BLOWER AMPERAGE	AGITATOR AMPERAGE
POSITIVE DISPLACEMENT	4 1/2	135	15 @ 240V	10 @ 240V

OPTIONS (See diagram at right)

- bushing reducer - 4" to 3"
- 5" (12.7 cm.) standard duty wheel package or heavy duty locking wheel package
- hopper extension - 44"W x 20"D x 32"H
(112cm. W x 51cm.D x 81.3cm.H)

These options will offer the user increased capacity and production rate, portability, and varying sizes of hose while satisfying export requirements.

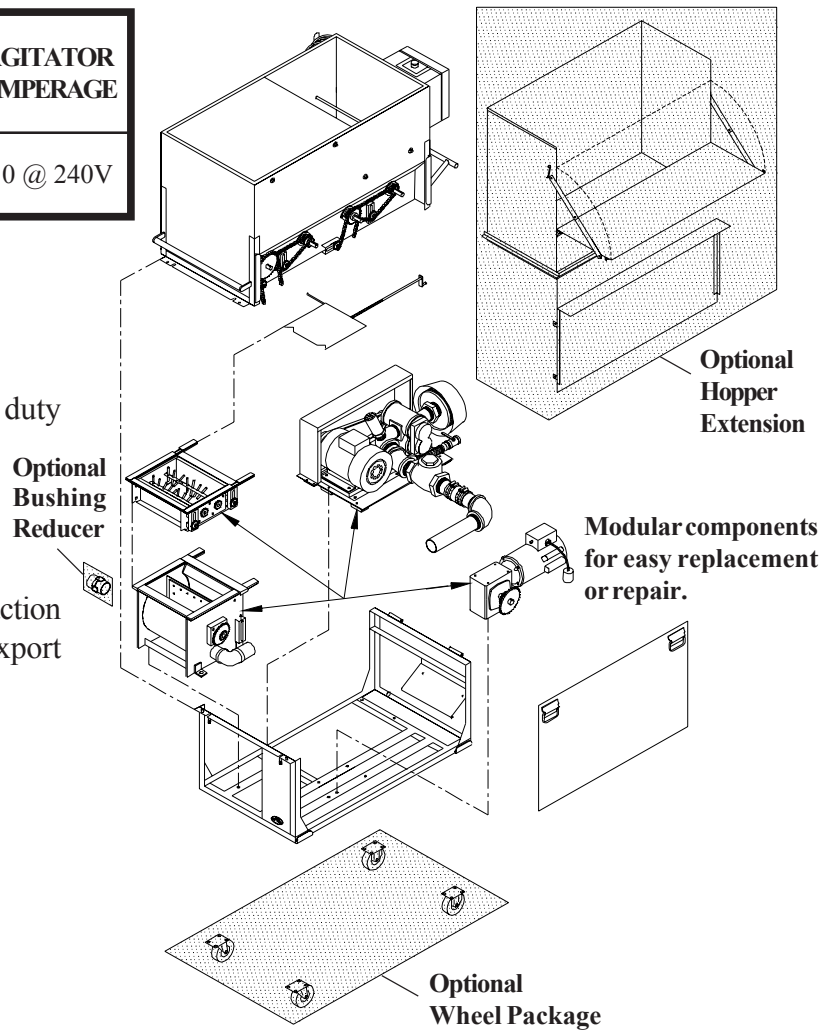

ALL-FIBER MACHINE - THEORY OF OPERATION

(See diagram at right)

This unit is designed to accept all fiber materials into the hopper area of the machine, passing through a multi-step agitation system and dropping into the rotating airlock feeder. The airlock feeder has a crankgate control providing precision feeding of fiber for open blowing, sidewall blowing, and spray-on applications. Fiber is then rotated to bottom of airlock where air from the blower motor pushes fiber from the rotating chambers through the hose. Material and air is prevented from escaping into the machine while in the airlock by six rubber seals which conform to the airlock inner wall as the chambers revolve. The positive displacement blower unit is designed to blow air using high pressure and low air volume with minimal attic dust. (Fiber **does not** pass through the blower.) This reduces hose plugging problems and gives longer blower life.

Note: All-fiber/airlock machines provide slightly less coverage than thru-blower machines. Airlock machines cannot duplicate the high speed (13,000 r.p.m.) conditioning effect of fiber passing through the blower. Airlock machines blow the fiber closer to settled density which eliminates the need for over blowing material to compensate for progressive settling.

